



Bartók Headphone DAC

User Manual

DCS310659 - V04



Document information

Published on: 02/02/2024
Document ID: DCS310659 - V04
Software version: 2.0x

Copyright

Copyright © 2024 Data Conversion Systems Ltd. All Rights Reserved.
Information contained in this manual is subject to change without notice, and whilst it is checked for accuracy, no liabilities can be accepted for errors.
dCS® and Ring DAC® are registered trademarks of Data Conversion Systems Ltd.
dCS is Data Conversion Systems Ltd. Company registered in England No. 2072115.
This product incorporates the following dCS proprietary technology: Ring DAC
Other product and company names may be trademarks or registered trademarks of other companies, and are the property of their owners. They are used only for explanation, without intent to infringe.

Intended purpose

This document advises users how to set up, use and configure the product.

Conventions in this document

This document uses the following safety notices and tips:



WARNING

Indicates a hazardous situation which, if not avoided, could result in death or serious injury.



CAUTION

Indicates a hazardous situation which, if not avoided, could result in moderate injury, damage the product, or lead to loss of data.

NOTICE

Indicates an important situation which, if not avoided, may seriously impair operations.



Additional information relating to the current section.

Contact address

Data Conversion Systems Ltd.
Unit 1, Buckingham Business Park,
Anderson Road,
Swavesey,
Cambridgeshire, CB24 4AE
UK

Contents

Safety	5
Getting started	7
What's in the box	7
Where to place the unit	7
Recommended cables and connectors	7
Overview	9
Front panel	9
Rear panel	12
Setting up	16
Connecting the power supply	16
Switching the unit on and off	16
Connecting analogue outputs	17
dCS Mosaic	19
Connecting PCM inputs	20
Connecting a computer	21
Clocking	23
Using Power Link	26
Using the Bartók Headphone DAC	27
Navigating the menus	27
Changing the input	27
Changing the output	27
Changing the volume	28
Playing music with Apple AirPlay	28
Playing music with Spotify Connect	28
Playing music from streaming services	28
About MQA files	29
Using Roon	29
Playing music from a USB storage device	30
Settings	31
Overview of the menus	31
Software menus	32
Renaming digital inputs	33
Renaming your Bartók Headphone DAC	33
Viewing information about the unit	34
Audio settings	35

Unit settings	38
Configuration settings	42
Display settings	44
System tests	45
Updating the software	45
Specifications	46
About the software	47
Maintenance	48
Replacing a blown mains fuse	48
Cleaning the unit	49
Troubleshooting	50
Support	52
Contact details	52
Limited warranty	53
General information	53
Warranty exclusions	53
Obtaining service	53
Operating conditions	54
Compliance	55
FCC compliance statement	55
Made for iPhone® and iPad®	55
Works with Apple AirPlay	56

Safety

The following statements are required to comply with U.S. safety standard UL60065.



WARNING

To prevent possible hearing damage, do not listen at high volume levels for long periods of time. Prolonged exposure to high volumes when using headphones may damage your hearing.



CAUTION

Read and comply with all safety messages and instructions in this document.

- Follow the cleaning instructions in this document.
- Only install the unit according to the instructions in this document.
- Do not spill liquid on the unit or allow it to get wet.
- Do not install the unit near heat sources.
- Use only the attachments and accessories specified by dCS.



CAUTION

To prevent the risk of electric shock and ensure the best audio performance, connect the unit to mains earth (ground) using the correct power cable.

- A grounding type plug has two blades and a grounding prong, which is provided for safety. If the provided plug does not fit into your outlet, contact a qualified electrician.
- Do not use the power cable if it is damaged.
- If this unit is not being used for a long period of time, disconnect the unit from the power supply.
- During lightning storms, disconnect the unit from the power supply to prevent power surges.



CAUTION

The safety covers on the unit protect you from electric shock.

- Do not remove the safety covers from the unit.
- If you do remove the safety covers from the unit, it invalidates the warranty.



NOTICE

If the unit is damaged, do not use it and contact a qualified service engineer. Possible causes of damage to the unit include the following:

- Liquid is spilled on the unit.
- A heavy object falls on the unit.
- The unit is exposed to rain or moisture.
- The unit is dropped.

NOTICE

The voltage setting of the unit must match the local supply voltage. If you use the unit with a different voltage from the local supply, it may damage the unit and invalidate the warranty.

- The voltage setting on the unit is shown on the serial number label on the rear of the unit.
- To change the voltage setting of the unit, contact your dealer.

NOTICE

Damage caused to the unit by misuse of a mains regenerator or by a malfunctioning mains regenerator is not covered by the warranty.

- We do not recommend the use of mains regenerators.
- If you want to use a mains regenerator with variable voltage and frequency, set the voltage to match your local voltage. Set the frequency to either 50Hz or 60Hz.
- Do not change the output voltage of the mains generator while it is connected to the unit.

NOTICE

If the unit is cold and is moved into a warm room, condensation may form inside the unit. Condensation may interfere with the normal operation of the unit. If the unit has been kept somewhere cold, remove all packaging and leave it for 1-2 hours before using it to allow it to reach room temperature.



This product is not suitable for operation at altitudes above 2000m.



This product is lead-free and complies with the RoHS directive.



The symbol indicates that this product should not be treated as normal household waste. Recycle this product at an approved collection facility.

Getting started

What's in the box

The box contains the following items:

- dCS Bartók Headphone DAC
- User Guide
- Software Quick Start Guide
- Quick Reference Guide for the Mosaic Control app
- Power cable
- Spare fuses

If an item is missing from the box, contact your dealer.

Bartók Headphone DAC is intended to be controlled by the dCS Mosaic Control app. A dCS Universal IR remote control is available as an optional extra.



We recommend that you keep the original packaging of the unit. If you need to order replacement packaging, see www.dcsaudio.com.

Where to place the unit

To get the best sound quality, place the Bartók Headphone DAC on a separate shelf or rack from other audio equipment.

- Place each unit on a firm, vibration-free base.
- Ensure you can easily connect the unit to the other parts of your system.
- Leave free space around the unit to allow for ventilation.
- To ensure the unit is level, adjust the feet on the bottom of the unit. The maximum height adjustment is 3 mm (1/8").

Recommended cables and connectors

We recommend the following cables and connectors for use with the unit. We supply "commercial" cables with the unit, but you can use cables and connectors of your preferred quality.

NOTICE

Heavy or inflexible power cables may damage the connectors on the unit.



Some "audiophile" cables have unusual grounding or screening arrangements, or they don't have the correct characteristic impedance. If you have difficulty using such cables but the problem disappears when you use standard cables, contact your cable manufacturer.

Digital inputs

Input	Recommended cable and connector
AES / EBU	110 Ω screened, twisted pair cables fitted with one male 3 way XLR connector and one female 3 way XLR connector.
Word Clock / SPDIF BNC	75 Ω coax cables fitted with BNC connectors.
SPDIF RCA	75 Ω coax cables fitted with RCA phono connectors.
Toslink	Toslink fibre-optic cables.
Network	RJ45 Ethernet cable.
USB	Standard screened USB 2.0 cable fitted with one type 'A' connector and one type 'B' connector. The internal screen must be connected at both ends.



The Word Clock sockets require a simple DC-coupled connection. If you use capacitor-coupled cables or cables with built-in networks, the interfaces may not work correctly.

Analogue outputs

Output	Recommended cable and connector
Balanced output	Screened, twisted pair cables fitted with one male 3 way XLR connector and one female 3 way XLR connector.
Unbalanced outputs	Coax cables fitted with RCA phono connectors.

Overview

Front panel

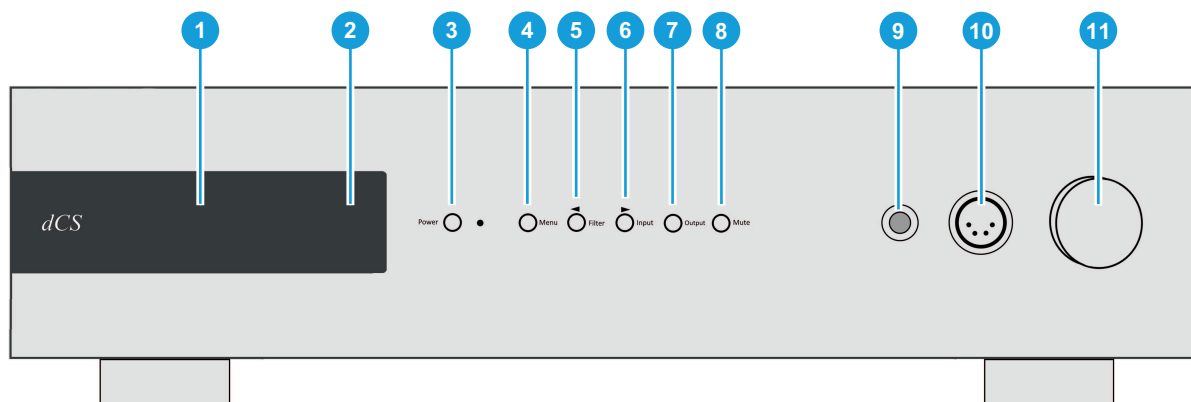

Item	Description
1	<p>Display</p> <p>Displays menus and information about the current input, for example, track name and artist.</p> <p>► For more information, see "Display" on the next page.</p>
2	<p>Remote control receiver</p> <p>Aim the remote control at the remote control receiver.</p>
3	<p>Power button</p> <p>Press to switch on the unit. Press to enter sleep mode or wake from sleep mode. When in sleep mode, the adjacent blue LED is lit. Press and hold until SWITCHING OFF is displayed to switch off the unit. In a menu, press to close the menu.</p>
4	<p>Menu button</p> <p>Press to open the main menu. In a menu, press to select an item. When a USB storage device is inserted in the <i>USB2</i> socket, press and hold for 2 seconds to open the file browser.</p>
5	<p>◀ Filter button</p> <p>Press to change the PCM filter setting when receiving PCM data, or the DSD filter when receiving DSD data.</p> <p>► For more information, see "Changing the PCM filter" on page 35.</p> <p>In a menu, press to go to the previous page or item. In a track list, press to go to the previous track.</p>
6	<p>▶ Input button</p> <p>Press to cycle through the available digital inputs.</p> <p>► For more information, see "Changing the input" on page 27.</p> <p>In a menu, press to go to the next page or item. In a track list, press to go to the next track.</p>
7	<p>Output button</p> <p>Press to change the output setting between line output and headphone output. The icon in the lower right corner of the display indicates which outputs are selected. When the file browser is open, press to go up to the folder at the level above.</p>
8	<p>Mute button</p> <p>Press to mute or unmute the audio.</p>

Item	Description	
9	Unbalanced output	Headphone unbalanced connection (jack socket).
10	Balanced output	Headphone balanced connection (XLR connector).
11	Rotary control	Turn to change the volume. If the unit is set to balance mode, turn to adjust the balance. In a menu, turn to the right to go to the next page, and turn to the left to go the previous page.

Display

When streaming music from the network or a USB device, the display shows the following information:

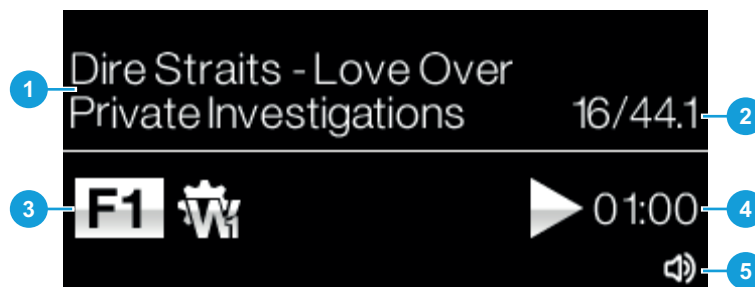

Area	Description
1	Information about the current song, for example, the artist, album name, track name, or file name
2	Data rate (word length and sample rate for PCM, or DSD or DSDx2)
3	Status icons ▶ For more information, see "Status icons" on the facing page.
4	Play/Pause icon and track elapsed time
5	Output mode















When a digital input is selected, or the network input is selected but not active, the display shows the following information:



Area	Description
1	Current input
2	Data rate (word length and sample rate for PCM, or DSD or DSDx2)
3	Status icons ▶ For more information, see "Status icons" below.
4	Current volume
5	Output mode

Status icons

In normal operation, status icons are shown on the display.

Icon	Description
	Filter setting when receiving PCM data
	Filter setting when receiving DSD data
	Clocking sync mode
	Settings are locked
	Phase is inverted
	Channels are swapped
	Decoding MQA format data
	Decoding MQA Studio format data
	Display is set to automatically turn off
	Incorrect clock detected (AES and SPDIF inputs only)
	Headphone outputs are active
	Crossfeed is on
	Line outputs are active
	Headphone amplifier disabled

Headphone outputs

You can connect your headphones to either the balanced output or unbalanced output on the front panel. These outputs are suitable for headphones with an impedance of 30Ω or higher.

Output connection type	Front panel connection
Balanced	4 way XLR socket
Unbalanced	Jack socket

 To switch between line output and headphone output, press the *Output* button.

Rear panel

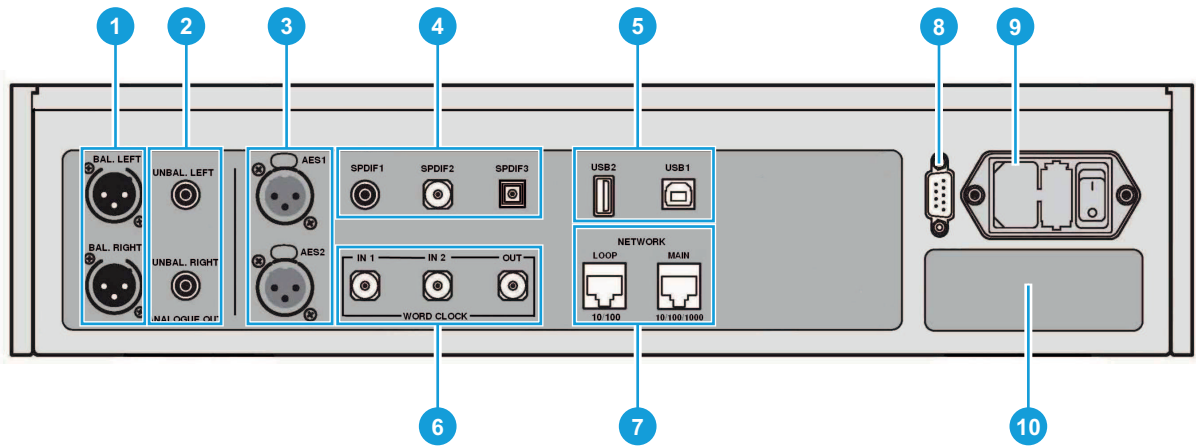

Item	Description
1	Balanced outputs XLR connectors to connect to a preamplifier or power amplifier. ▶ For more information, see "Line outputs" on the facing page.
2	Unbalanced outputs RCA connectors to connect to a preamplifier or power amplifier. ▶ For more information, see "Line outputs" on the facing page.
3	AES digital inputs Connectors for digital audio equipment. ▶ For more information, see "Digital inputs" on the facing page.
4	SPDIF digital inputs Connectors for digital audio equipment. ▶ For more information, see "Digital inputs" on the facing page.
5	USB sockets USB1 and USB2 sockets. ▶ For more information, see "USB sockets" on the facing page.
6	Word clock inputs and output Connectors to accept word clock from source equipment or a master clock. ▶ For more information, see "Word clock inputs and output" on page 14.
7	Network socket Socket for streaming data from the local network or the Internet. ▶ For more information, see "Network socket" on page 14.
8	RS-232 socket Socket for remote control or Power Link. ▶ For more information, see "RS-232 socket" on page 14.
9	Power socket Power is connected via a standard IEC320 connector, with a power switch and a fuse holder.
10	Label Information about the unit's serial number and nominal voltage.

Line outputs

The balanced and unbalanced outputs on the unit are independent, which allows you to connect each output to a different amplifier.

Connect balanced outputs to true balanced inputs only. The outputs are electronically balanced and floating, which reduces hum or interference picked up by the cable. There are three connections:

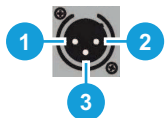

Pin 1: Screen / ground

Pin 2: Signal +

Pin 3: Signal -



The balanced outputs do not work correctly when they are connected to an unbalanced input.

Digital inputs

AES digital inputs

You can use the *AES1* and *AES2* inputs individually at data rates up to 192 kS/s or DSD/64.

If the **DUAL AES** menu page is set to **ON** or **AUTO**, you can use *AES1* and *AES2* together as a Dual AES pair. Dual AES supports the following inputs:

- PCM data (24/88.2 to 24/384)
- dCS-encrypted DSD data from Vivaldi, Rossini, Scarlatti, and Paganini Transports
- DoP data (DSD/64 or DSD/128 over PCM)

► For more information, see "Enabling and disabling Dual AES" on page 39.



Dual AES works correctly only when the source generates Dual AES data.

SPDIF digital inputs

SPDIF1 and *SPDIF2* are inputs that accept sample rates up to 192 kS/s, including DoP/64.

SPDIF3 is a Toslink optical receiver that is guaranteed at up to 96 kS/s, but may be usable at up to 192 kS/s.



Before you use the *SPDIF3* input, remove the dust cover from the port.

USB sockets

The *USB1* socket is a galvanically isolated 'B' type socket. It accepts PCM data at up to 24 bits / 384 kS/s from a Windows™ PC, Apple Mac™, or sound server. The socket also accepts DSD/64 or DSD/128 files that are in DoP format.

The *USB1* socket can operate in two audio classes:

- Class 1, which accepts files up to 96 kS/s. No additional drivers need to be installed on the connected computer.
- Class 2, which accepts files up to 384 kS/s, DSD/64 or DSD/128 in DoP format.
 - On Apple desktops and notebooks running macOS 10.6.3 or later, or computers running Windows™ 10 or later, no additional driver needs to be installed.

- On computers running Windows™ 7, 8 or 8.1, the dCS USB Class 2 audio driver needs to be installed. If you require the dCS USB Class 2 audio driver, contact dCS support at support@dcsaudio.com.

► For more information, see "Setting the USB audio class" on page 40.



The *USB1* input has been tested with various PCM streaming programs on Windows™ 10, Windows™ 8.1, and macOS 10.11. However, USB audio connectivity may not be available with all devices, operating systems, or software.

The *USB2* socket is an 'A' type socket. It can support PCM music files in formats at up to 24 bits / 384kS/s or DSD/128. The connected USB device must be both of the following:

- A USB flash drive or low-powered USB hard drive, with the suggested maximum size of 32 GB
- In FAT16, FAT32, or un-encrypted NTFS format

The *USB1* and *USB2* sockets work in true asynchronous USB mode, which ensures the unit is not affected by clock jitter from connected devices.

Word clock inputs and output

The *WORD CLOCK IN 1* and *WORD CLOCK IN 2* sockets accept the following inputs:

- Standard word clock from the source equipment
- A master clock generating word clock at 44.1, 48, 88.2, 96, 176.4, or 192 kHz

The unit can only lock when the clock frequency is an exact multiple of the data rate.

When the sync mode is set to **MASTER** on the unit, the *WORD CLOCK OUT* socket carries standard word clock at 44.1 or 48 kHz. You can connect the *WORD CLOCK OUT* socket to the Word Clock Input on suitable source equipment, for example a dCS CD Transport.

Word clock is used only for synchronisation and does not carry digital audio data.

► For more information, see "Clocking" on page 23.

Network socket

The *NETWORK MAIN* connection is an RJ45 socket that allows you to stream music from the local network or Internet. The unit streams music files at up to 24 bits / 384 kS/s, or DSD/64, or DSD/128. The network interface runs in asynchronous mode and is galvanically isolated.

The *NETWORK LOOP* connection is not supported.



CAUTION

The metal contacts of the network sockets can be damaged by accidentally inserting the wrong connector. When a network socket is not in use, replace the dust cover.

RS-232 socket

The RS-232 socket is a 9-way male D-type connector. It can operate in two modes:

- Text mode, which allows communication with a third-party control system. The baud rate is 115200. To view a list of available commands in text mode, send a HELP command from the connected system.
- Binary mode, which is for factory use only. The baud rate is 4800.

The connections for the pins in the socket are the following:

- Pin 2: unit transmit

- Pin 3: unit receive
- Pin 5: ground
- Shell: cable screen and drain wire



You can change the RS-232 mode in the **UNIT SETTINGS** menu.

- ▶ *For more information, see "Changing the RS-232 mode" on page 40.*

You can use the RS-232 socket to connect your Bartók DAC to a Rossini Master Clock, creating a Power Link.

- ▶ *For more information, see "Using Power Link" on page 26.*

Setting up

Connecting the power supply

Use the supplied power cable to connect your Bartók Headphone DAC to the power supply.

1. At the rear of the unit, insert the power cable into the power socket.

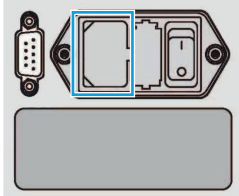

2. Connect the plug to a power supply.

Switching the unit on and off

At the rear of the unit, there is a power rocker switch next to the power cable. There is also a *Power* button on the front panel.

To switch on the unit:

1. On the rear of the unit, press the power rocker switch to the *I* position.

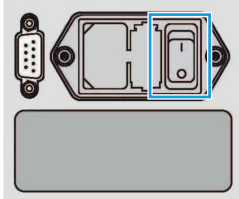

2. Press the *Power* button.

To switch off the unit:

- Press and hold the *Power* button until **SWITCHING OFF** is displayed.

Using sleep mode

Sleep suspends the unit in its current state, but keeps it ready for quick use.

- To enter sleep mode, press the *Power* button.
The display turns off, the front panel is disabled, and all outputs are muted. The *Power* light turns on.
- To wake up from sleep mode, press the *Power* button.



To prevent screen burn-in of the display, switch the unit off or put it in sleep mode when not in use.

Connecting analogue outputs

You can connect your Bartók Headphone DAC to preamplifiers and power amplifiers. The unit has two types of analogue output connections: balanced and unbalanced. These outputs are independent, which allows you to connect each output to a different amplifier.

Output connection type	Cable to use
Balanced	XLR cable
Unbalanced	RCA phono cable

 Connecting the unit's balanced output to an unbalanced input using an XLR cable is not recommended, as it results in hissing noises, unstable levels, and a thin sound.

Connecting a preamplifier

You can connect a preamplifier to the balanced or unbalanced outputs.

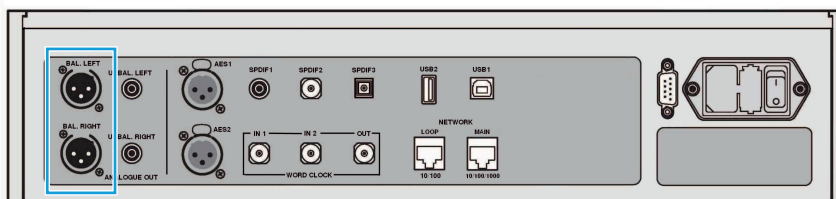

1. Switch on the preamplifier and set it to a low volume.
2. Connect cables to the rear of the unit.
 - If you are using the balanced outputs, connect XLR cables to the *BAL LEFT* and *BAL RIGHT* sockets.

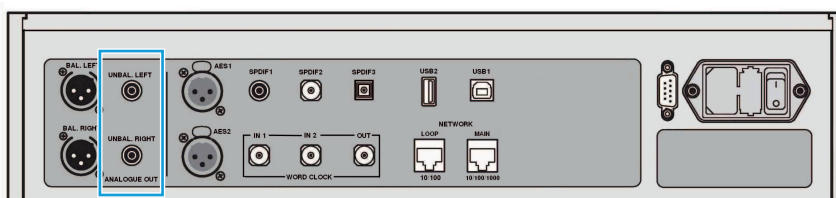

- If you are using the unbalanced outputs, connect RCA phono cables to the *UNBAL LEFT* and *UNBAL RIGHT* sockets.



3. Connect the other end of the cables to the preamplifier.
 -  The inputs may be labelled CD or AUX.
4. Turn the rotary control on the unit to increase the volume to maximum. -0.0 dB is displayed.
5. Play music on the unit.
 - ▶ For more information, see "Using the Bartók Headphone DAC" on page 27.
6. While music is playing, slowly increase the preamplifier volume to the desired level.

 If you see the headphone icon  in the lower right hand corner of the display, press the *Output* button to change to line output .

We recommend using the 2 V line level setting with the preamplifier, as the 6 V setting can cause the preamplifier to distort.

- ▶ For more information, see "Changing the line output level" on page 39.

Connecting a power amplifier

You can connect a power amplifier directly to the balanced or unbalanced outputs.

1. Turn the rotary control on the unit to set the volume to -40.0 dB.
2. Connect cables to the rear of the unit.
 - If you are using the balanced outputs, connect XLR cables to the *BAL LEFT* and *BAL RIGHT* sockets.

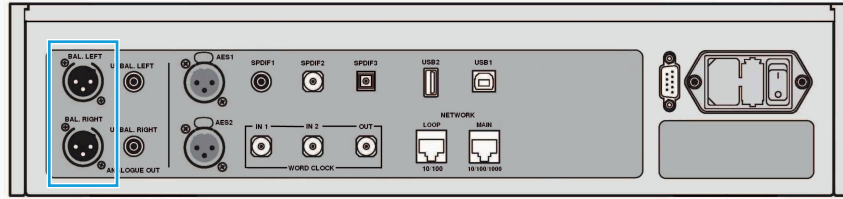

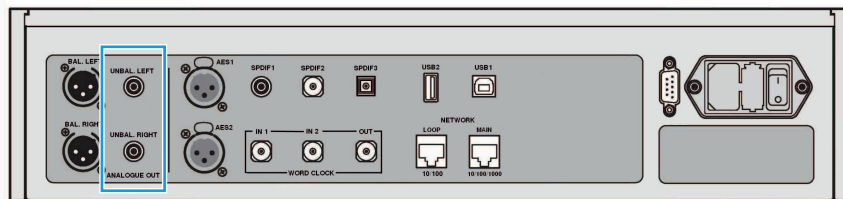

- If you are using the unbalanced outputs, connect RCA phono cables to the *UNBAL LEFT* and *UNBAL RIGHT* sockets.



3. Connect the other end of the cables to the power amplifier.
4. Switch on the power amplifier.
5. Play music on the unit.
 - ▶ For more information, see "Using the Bartók Headphone DAC" on page 27.
6. While music is playing, slowly turn the rotary control on the unit to increase the volume to the desired level.



If you see the headphone icon  in the lower right hand corner of the display, press the *Output* button to change to line output .

If you need to set the volume on the unit higher than -10.0 dB or lower than -30 dB to reach a comfortable listening level, you may need to adjust the line output level.



- ▶ For more information, see "Changing the line output level" on page 39.

Connecting headphones

You can connect your headphones to either the balanced output or unbalanced output on the front panel. For the best sound quality, we recommend not connecting balanced and unbalanced headphones at the same time.

1. Turn the rotary control on the unit to set the volume to -40.0 dB.
2. Connect your headphones to the sockets on the front panel.



If you see the line output icon  in the lower right hand corner of the display, press the *Output* button to change to headphone output .

3. Play music on the unit.
4. While music is playing, slowly turn the rotary control on the unit to increase the volume to the desired level.
5. If the volume setting for a comfortable listening level is higher than -10 dB or lower than -30 dB, try changing the headphone output level.

- ▶ For more information, see "Changing the headphone output level" on page 39.



If a warning icon  is displayed, the headphone amplifier has overheated or there is a DC error. Check the impedance of your headphones.

dCS Mosaic

dCS Mosaic is a bespoke collection of hardware and software modules that allow you to access your digital music. With dCS Mosaic, you can stream content from the following:

- Local streaming sources, such as a music server on your network or using Apple AirPlay
- Internet services, such as Spotify, TIDAL, Qobuz and Deezer
- Internet Radio
- Podcasts via Airable

The Mosaic Control app

Mosaic Control is an app for your iOS or Android mobile device. With the Mosaic Control app you have access to a vast library of music through a simple, yet powerful interface. You can use the app to:

- Browse media from various streaming services
- Manage settings and configuration options for your dCS products

To download the Mosaic Control app, visit the app store on your iOS or Android device and search for dCS Mosaic.



Help using the Mosaic Control app

To view the User Guide for the Mosaic Control app, visit <https://dcs.community/t/dcs-mosaic-user-guide/>

Connecting to your network

You can connect your Bartók Headphone DAC to your network using an Ethernet cable. After the unit is connected to the network, you can stream content from local sources, such as a music server on your network, or from Internet services.

Before you connect to the Internet, ensure you have the following items:

- A wireless router with an Ethernet connection.
- A mobile device with the Mosaic Control app installed.
 - ▶ For more information, see "dCS Mosaic" above.
- Optional: A music server, such as a Network Attached Storage (NAS) server. The music server must be UPnP (Universal Plug and Play) compatible, and must be connected to the router via an Ethernet cable.

We fully test our products with the MinimServer UPnP server software. For more information about MinimServer, visit www.minimserver.com

- 💡 For more information about configuring your network for dCS Mosaic, contact your dealer.

To connect your Bartók Headphone DAC to your network:

1. At the rear of the unit, connect an Ethernet cable to the *NETWORK MAIN* socket.

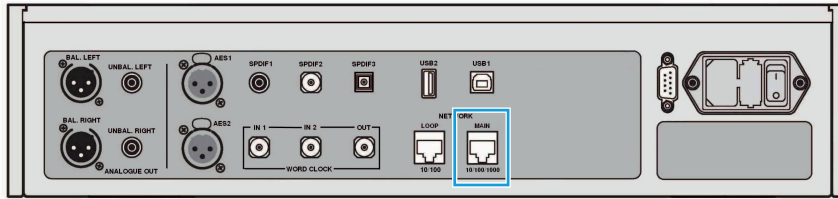

2. Connect the other end of the Ethernet cable to a router.
3. On your mobile device, connect to the same network as your router.
4. On your mobile device, open the Mosaic Control app and connect to your Bartók Headphone DAC.
5. Download the online Mosaic User Guide from:
<https://dcs.community/t/dcs-mosaic-user-guide>

Connecting PCM inputs

Your Bartók Headphone DAC has five Pulse-Code Modulation (PCM) input ports. You can use these ports to connect audio equipment to the unit, for example, CD transports, DVD players, or upsamplers.

There are two types of PCM ports:

- AES (Audio Engineering Society)
- SPDIF (Sony/Philips Digital Interface)

- 💡 When listening to music from audio equipment that is connected to the PCM ports on your Bartók Headphone DAC, the unit may display 0 bits between tracks or if no music is playing. This is because no data is being transferred.

Connecting a single AES or SPDIF input

Most digital audio source equipment is fitted with at least one digital output, which is usually an RCA phono connector. Satellite receivers usually have a Toslink optical output.

1. At the rear of your Bartók Headphone DAC, connect a suitable cable to an *AES* or *SPDIF* socket.

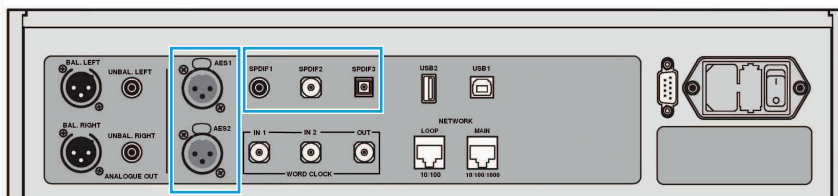

2. Connect the other end of the cable to the source equipment.
3. Switch on the source equipment.
4. If possible, play music on the source equipment to generate an audio signal.
5. Press the *Input* button to select one of the following inputs: **AES1**, **AES2**, **SPDIF1**, **SPDIF2**, or **SPDIF3**.

After you have selected the input, the display shows the bit rate and format of the current music.

- 💡 If the **AUDIO** sync mode icon  is not displayed, select it on the **UNIT SETTINGS > SYNC MODE** menu page.

Connecting a Dual AES input

Some audio equipment can output in Dual AES. Example products include a dCS SACD transport, a dCS upsampler, or a sound server.

1. Use XLR cables to connect your Bartók Headphone DAC to the source equipment. Ensure the cables are not swapped.
 - Connect the AES1 (or AES A) output on the source equipment to the **AES1** socket on the unit.
 - Connect the AES2 (or AES B) output on the source equipment to the **AES2** socket on the unit.

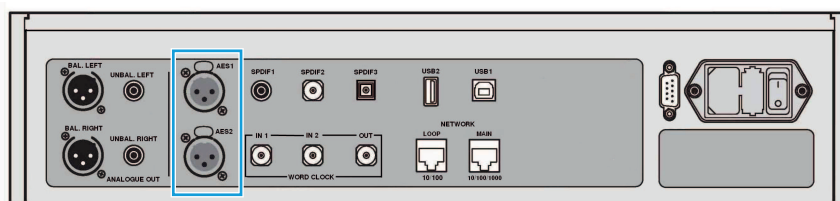

2. Switch on the source equipment.
3. If possible, play music on the source equipment to generate an audio signal.
4. Ensure that the **UNIT SETTINGS > DUAL AES** menu page is set to **AUTO**.
 - ▶ *For more information, see "Enabling and disabling Dual AES" on page 39.*
5. Press the *Input* button repeatedly until the input is **AES1**.
The unit locks to the source. **AES1+2** and the format of the current music is displayed.

- 💡 If the **AUDIO** sync mode icon  is not displayed, select it on the **UNIT SETTINGS > SYNC MODE** menu page.

- 💡 Dual AES mode is not available if the sample rate is 44.1 or 48 kS/s. With these sample rates, the input changes to **AES1**.

Connecting a computer

You can connect a computer to the **USB1** socket on your Bartók Headphone DAC. For best results, we recommend using a premium music streaming program instead of software included with the operating system.

The **USB1** socket can operate in two audio classes:

- Class 1, which accepts files up to 96 kS/s. No additional drivers need to be installed on the connected computer.
- Class 2, which accepts files up to 384 kS/s, DSD/64 or DSD/128 in DoP format.
 - On Apple desktops and notebooks running macOS 10.6.3 or later, or computers running Windows™ 10 or later, no additional driver needs to be installed.
 - On computers running Windows™ 7, 8 or 8.1, the dCS USB Class 2 audio driver needs to be installed. If you require the dCS USB Class 2 audio driver, contact dCS support at support@dcsaudio.com.

- ▶ *For more information, see "Setting the USB audio class" on page 40.*

💡 The **USB1** input has been tested with various PCM streaming programs on Windows™ 10, Windows™ 8.1, and macOS 10.11. However, USB audio connectivity may not be available with all devices, operating systems, or software.

1. Use a USB cable to connect a computer to the **USB1** socket on the rear of the unit.

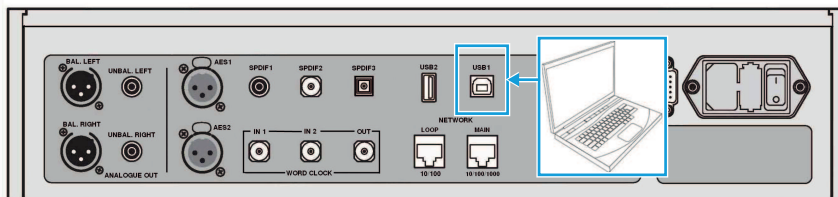

2. Press the **Input** button repeatedly until **USB1** is displayed.
3. If **M** is not displayed, set the **UNIT SETTINGS > SYNC MODE** menu page to **MASTER**. This is the default sync mode for USB and network inputs.
 - ▶ For more information, see "Setting the clocking sync mode" on page 38.

💡 If the USB input stops responding on the unit, do the following:

1. Disconnect the USB cable from the unit.
2. Change the USB audio class, then change it back to its original setting.
 - ▶ For more information, see "Setting the USB audio class" on page 40.
3. Reconnect the USB cable to the unit.

Selecting Bartók Headphone DAC as the audio output device on your computer

To listen to music from your computer on the unit, you may need to change your preferred audio output device.

macOS™

1. Select **Finder**.
2. Select the **Go** tab.
3. Select **Utilities > Audio MIDI Setup**.
4. Use the right mouse button to select **dCS Bartok DAC USB ...**
5. Select **Use this device for sound output**.
6. To get the best sound quality, set the format to **384000.0Hz** and **2ch-24bit Integer**.
7. Close **Audio MIDI Setup**.

Windows 10™, Windows 8.1™, or Windows 7™

1. Open the Control Panel and select **Sound**.
2. Select the **Playback** tab.
3. Use the right mouse button to select **dCS Bartok DAC Audio**
4. Select **Set as Default Communication Device**.
5. To get the best sound quality:
 - a. Select **Properties**.
 - b. Select the **Advanced** tab.
 - c. Select **24 bit, 384000 Hz (Studio Quality)**.
 - d. In the **Exclusive Mode** options, select both options.
6. Close the **Sound** window.

Clocking

Clock jitter is variation in the digital audio clock frequency, which can cause a loss of fine detail when listening to music.

The unit can do one of the following:

- The unit locks to the clock generated by the source equipment.
- The unit runs in Master mode for network and USB inputs. The unit uses its own internal clock instead of locking to the data or an external clock.
- The unit runs in Master mode and sends word clock to synchronise the source equipment, for example, a CD transport. This arrangement helps to reduce clock jitter.
- The unit and the source equipment both lock to a Master Clock. This is the best option to reduce clock jitter.

Connecting a Rossini Master Clock

The Rossini Master Clock provides the unit with simultaneous 44.1 kHz and 48 kHz word clocks.

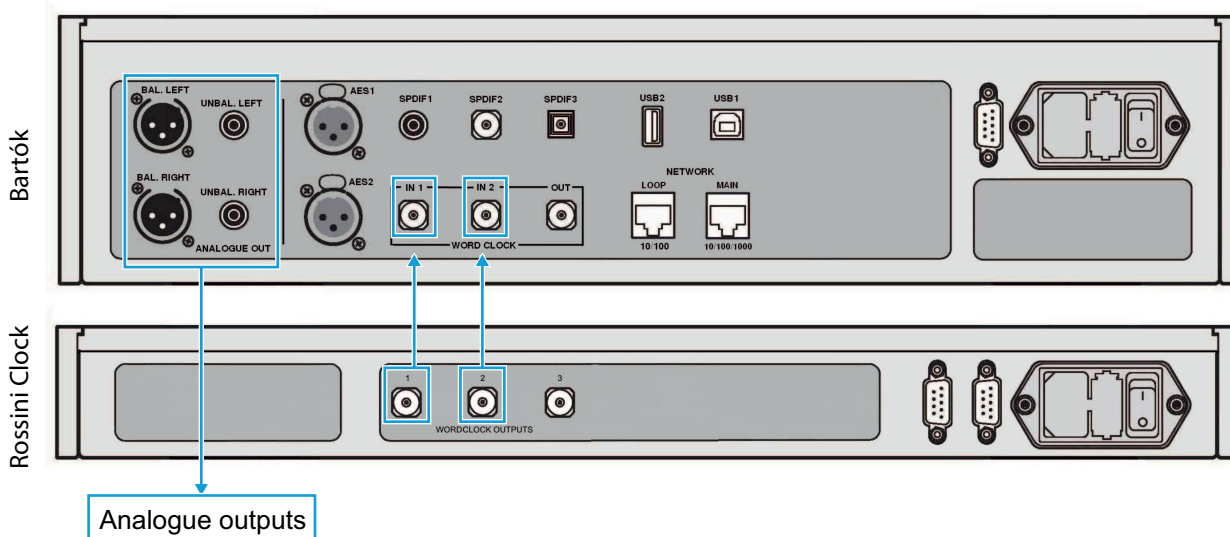

1. Press the *Input* button on the unit to select the input to lock to the clock.
You can choose the network and USB inputs because they operate in asynchronous mode.
2. Switch on the Rossini Master Clock.
3. Connect the Word clock output 1 on the Rossini Master Clock to the *WORD CLOCK IN 1* socket on the unit.
4. Connect the Word clock output 2 on the Rossini Master Clock to the *WORD CLOCK IN 2* socket on the unit.
5. Set the sync mode on the unit to **WORD CLOCK 1-2 AUTO**.
▶ For more information, see "Setting the clocking sync mode" on page 38.
The unit relocks to the Rossini Master Clock.



To lock source equipment connected to the AES or SPDIF inputs to a word clock, we recommend using a Vivaldi Master Clock. The Vivaldi Master Clock has more outputs than the Rossini Master Clock.

If you lock an AES or SPDIF input to a Master Clock, ensure the source equipment is locked to the same Master Clock, otherwise the music may have periodic clicks, drop-outs, or distortion.

Connecting a Rossini Master Clock and a Transport

The Rossini Master Clock has a third output, which is normally fixed at 44.1 kHz. You can use this output to clock another audio source, such as an SACD Transport.



On dCS Transports, Dual AES is the main output, carrying SACD data and upsampled CD data. To listen to CD playback in native 16/44.1 format, connect the AES 3 output or an SPDIF output on the Transport to the matching input on the unit.

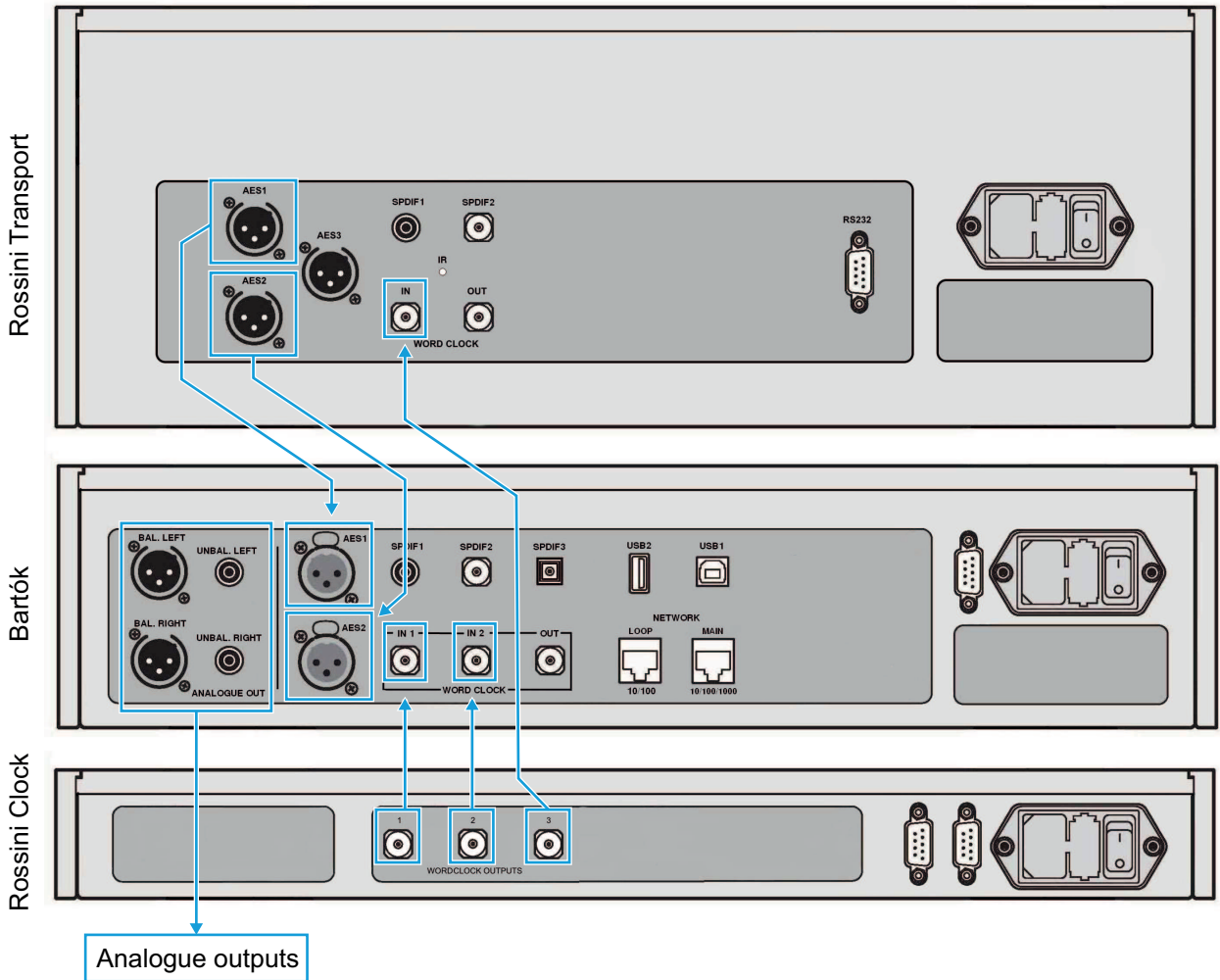

1. Connect the Word clock output 1 on the Rossini Master Clock to the *WORD CLOCK IN 1* socket on the unit.
2. Connect the Word clock output 2 on the Rossini Master Clock to the *WORD CLOCK IN 2* socket on the unit.
3. Connect the Word clock output 3 on the Rossini Master Clock to the Word Clock input on the Transport.
4. Press the *Input* button on the unit to select the input connected to the Transport.
5. Set the sync mode on the unit to **WORD CLOCK 1-2 AUTO**.
The Transport locks to the Rossini Master Clock.
 - ▶ *For more information, see "Setting the clocking sync mode" on page 38.*

Using the unit in Master Mode with a Transport

To reduce jitter when using the unit with a Transport, use the unit in Master Mode and slave the Transport to it.

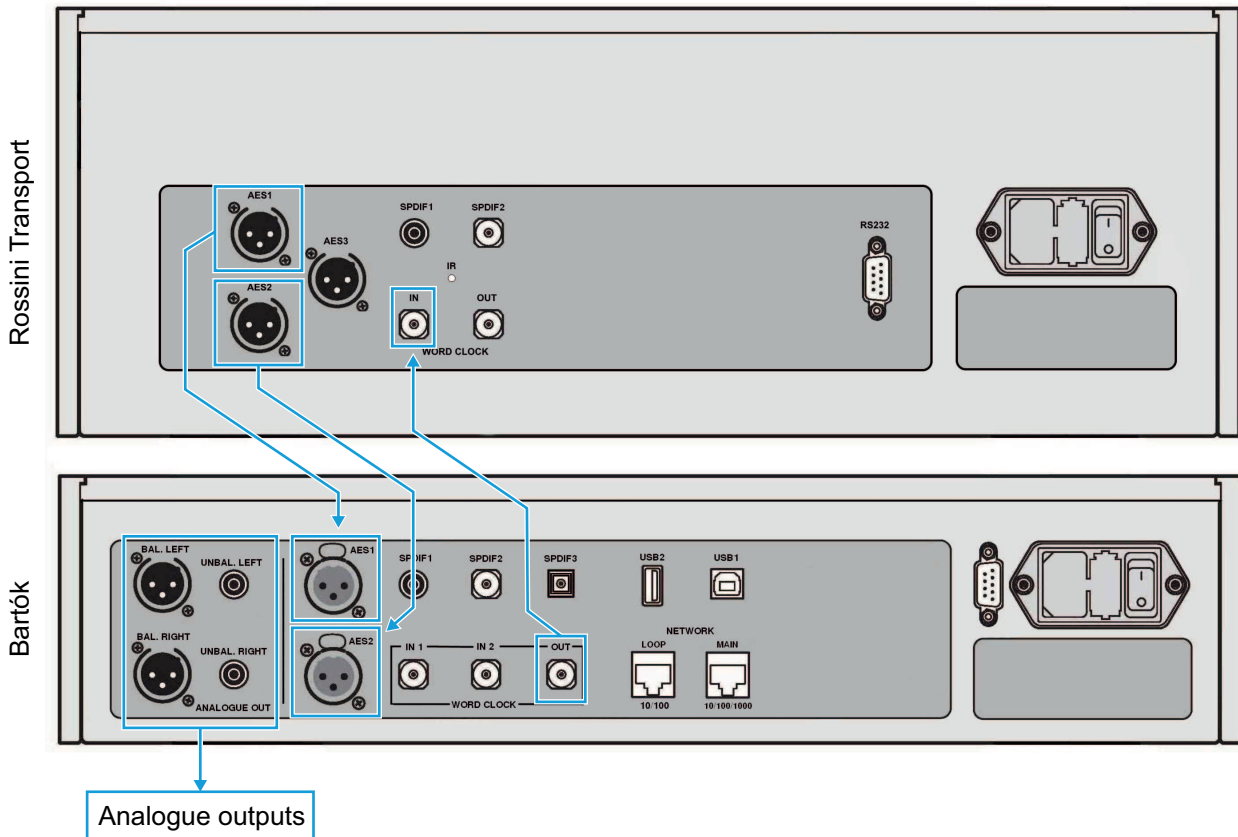

1. Press the *Input* button on the unit to select the input you want to use.
2. Connect the *WORD CLOCK OUT* socket on the unit to the Word Clock input on the Transport.
3. Set the sync mode on the unit to **MM MASTER**.
 - ▶ For more information, see "Setting the clocking sync mode" on page 38.
 The Transport locks to the 44.1 kHz word clock from the unit.

Using Power Link

Power Link allows you to switch the Bartók Headphone DAC and a connected Rossini Master Clock on and off at the same time, or put them both in and out of sleep mode. To enable Power Link, connect the RS-232 socket on the rear of your Bartók Headphone DAC to the RS-232 socket on a Rossini Master Clock.

Power Link requires a screened RS-232 cable, which is fitted with two 9-way female D-type connectors, wired pin-to-pin. This is known as a "straight-through" serial cable. Power Link does not work with a "null-modem" serial cable.

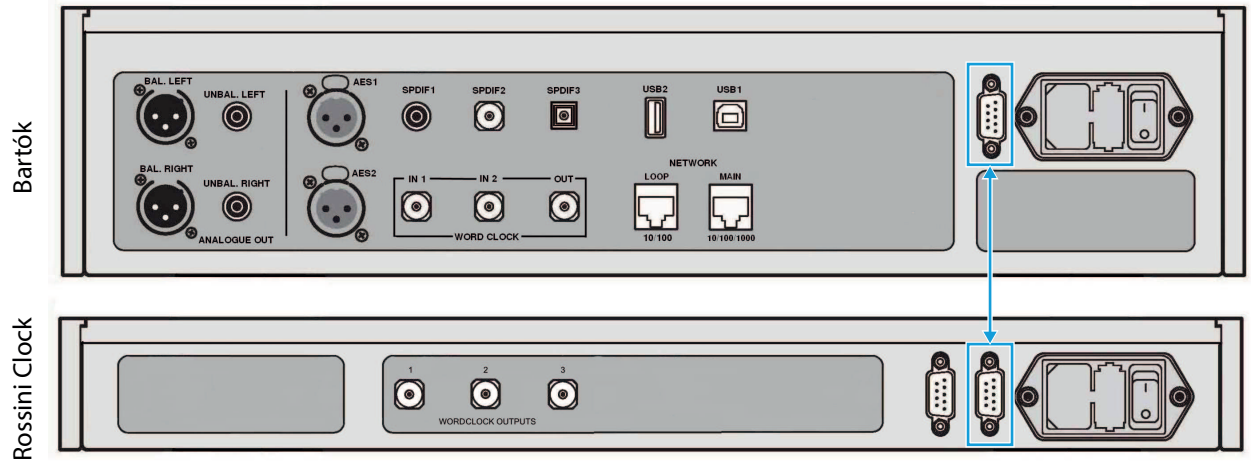

Power Link only works when the Bartók Headphone DAC and the connected Rossini Master Clock are in the same RS-232 mode. If you switch on the Rossini Master Clock before the unit, they both change to the same mode.

💡 The Rossini Transport does not support the Power Link feature.

Using the Bartók Headphone DAC

Navigating the menus

To navigate menus and lists on the unit, press the buttons on the front of the unit.

Button	Action
<i>Menu</i>	Open a menu or select an item.
▶ <i>Input</i>	Move to the next item.
◀ <i>Filter</i>	Move to the previous item.
<i>Power</i>	Close the menu.

 You can also use the rotary control to move to the previous or next page.

 In most menu screens, the menu closes after 7 seconds of inactivity.

Changing the input

To change the input, press the *Input* button.

Each time that you press the *Input* button, it advances through the list of available inputs. If an input is not connected or active, it is not included in the list.



The following inputs are available:

1. **NETWORK**
2. **AES1**
3. **AES2**
4. **AES1+2**
5. **SPDIF1** (RCA)
6. **SPDIF2** (BNC)
7. **SPDIF3** (Toslink)
8. **USB1**

 If the Dual AES setting is disabled, **AES1+2** is not shown in the list of inputs.

▶ For more information, see "Enabling and disabling Dual AES" on page 39.

Changing the output

To change the output, press the *Output* button to change between the line outputs  on the rear panel or the headphone outputs  on the front panel.

The icon in the lower right corner of the display indicates which outputs are selected.

Changing the volume

To change the volume, turn the rotary control on the front of the unit.

The volume changes in the following steps:

- Between 0 dB and -50 dB: 0.5 dB steps.
- Between -50 dB and -80 dB: 1 dB steps.

 The sound mutes below -80 dB.

Muting the unit

To mute or unmute the unit, press the *Mute* button.

When the unit is muted, **MUTE** appears on the display.

Playing music with Apple AirPlay

Use Apple AirPlay to wirelessly stream music from Apple devices. For more information, see www.apple.com/airplay.

1. Connect your Apple device to the same Wi-Fi network as your Bartók Headphone DAC.
2. Swipe down from the top-right of the screen on your Apple device to access the Control Center.
3. Tap the AirPlay icon  and then select your Bartók Headphone DAC.
When AirPlay is active, the unit's network input is automatically selected.

 To play music stored on an Android device in a similar way, use a UPnP (Universal Plug and Play) app such as BubbleUPnP.

Playing music with Spotify Connect

You can use your phone, tablet or computer as a remote control for Spotify.



1. Connect the device that runs the Spotify app to the same Wi-Fi network as your Bartók Headphone DAC.
2. Open the Spotify app and play a song.
3. At the bottom of the screen, select **Devices Available**.
4. From the list of devices, select your Bartók Headphone DAC.

For more information on how to set up and use Spotify Connect, see www.spotify.com/connect.

The Spotify software is subject to third-party licenses: www.spotify.com/connect/third-party-licenses.

Playing music from streaming services

You can use the Mosaic Control app to play music from online streaming services, such as Spotify, TIDAL, Qobuz, and Deezer. You can also listen to Internet Radio.

For more information, see the Mosaic Control User Guide at <https://dcs.community/mosaic-user-guide>.

About MQA files

MQA (Master Quality Authenticated) is an award-winning British technology that delivers the sound of the original master recording. The master MQA file is fully authenticated and is small enough to stream or download. Your Bartók Headphone DAC features a full MQA decoder.

For more information about MQA technology, see www.mqa.co.uk



MQA files that are streamed bit-perfect using a network connection or from the *USB2* socket are extracted and rendered to the original sample rate. The MQA icon and the decoded sample rate are shown on the display.

MQA files extracted by another device to 24/88.2 or 24/96 and then presented bit-perfect to the *USB1*, *AES* or *SPDIF* sockets are rendered to the original sample rate.

When listening to MQA files using a network connection, the Mosaic Control app displays the type of MQA stream.

NOTICE

If the original data in an MQA file has changed, the unit cannot decode the file.

For files to be identified as containing MQA audio and sent to the MQA decoder for authentication, the metadata in the file must include the correct MQA tags. If the metadata of an MQA file has been changed, removed or was never present (for example if the files were ripped from an MQA-encoded CD), the files will not be recognised and decoded.

To fix the metadata of MQA files, use the MQA Tag Renaming application. The application reads the MQA markers in the bit stream and applies the appropriate metadata tags to the files. For more information on the MQA Tag Renaming application, see: <https://www.mqa.co.uk/customer/tag435sdf43te>.

The MQA logo is a trademark of MQA Limited and is used under licence. MQA and the Sound Wave Device are registered trademarks of MQA Limited © 2016.

Using Roon

The Bartók Headphone DAC is Roon Ready.



If you have a Roon account, install Roon Core on your NAS drive or on a networked computer. You can then use Roon remote to control playback on your unit.

For more information about Roon, see <https://roonlabs.com/>

Playing music from a USB storage device

You can play music stored on a USB storage device. The connected USB device must be both of the following:

- A USB flash drive or low-powered USB hard drive, with the suggested maximum size of 32 GB
- In FAT16, FAT32, or un-encrypted NTFS format

NOTICE

To prevent the user interface of the unit from crashing, do not try to play non-audio files on the unit. If the user interface crashes, restart the unit.

To play music from a USB storage device:

1. Connect the USB storage device to the *USB2* socket.
2. Hold down the *Menu* button for 2 seconds to open the file browser.
3. Press the *Menu* button.
4. Find the file that you want to play.
 - Use the ◀ and ▶ buttons to highlight a file or folder.
 - Press the *Menu* button to open a folder.
 - Press the *Mute* button to move up a folder level.
5. Press the *Menu* button to start playing the highlighted file.
6. To close the browser, press the *Power* button.

The unit plays all files in the current folder, in the order that they are in, and then stops. To select a different folder or restart playback, open the file browser again.



You can also use the Mosaic Control app to play music from a USB storage device.

Settings







You can change settings in the menu on the unit, or using the Mosaic Control app.

► For more information, see "dCS Mosaic" on page 19.







To change settings for the unit using the Mosaic Control app, select  from the left of the screen on your mobile device.

Overview of the menus

The top menu consists of six menu pages.

Menu	Description
 INFO	View information about the unit, software versions and contact information.
 AUDIO SETTINGS	Change audio settings, such as the analogue output phase, filter settings and balance.
 UNIT SETTINGS	Change various settings, such as the output level and upsampling.
 CONFIG	Lock important settings, manage setting configurations, and reset the unit to factory conditions.
 DISPLAY	Change settings for the display on the unit, such as changing the brightness.
 GENERATOR	Run tests on the system and condition the unit.

Software menus

Menu	Sub menu	Description
 INFO	UNIT STATUS	View information about the unit.
	VERSION	View the current software versions.
	CONTACT	View dCS contact details.
	UPDATE	Update the software.
 AUDIO SETTINGS	PHASE	Change the output phase for analogue inputs.
	FILTER	Change the PCM filter.
	DSD FILTER	Change the DSD filter.
	CROSSFEED	Change the crossfeed setting.
	CH SWAP	Swap the channels.
	BALANCE	Adjust the balance.
 UNIT SETTINGS	SYNC MODE	Set the clocking sync mode for the current input.
	MAPPER	Control the data presented to the Ring DAC core
	OUTPUT MODE	Select line output or headphone output.
	OUTPUT LEVEL	Set a level for the line outputs.
	HP LEVEL	Set a level for the headphone output.
	AES1/2 DUAL	Enable or disable Dual AES.
	USB CLASS	Change the USB audio class.
	BUFFER MODE	Buffer the data to reduce clicks when the input rate changes.
	UPSAMPLING	Enable or disable DSD upsampling.
	RS232 MODE	Change the RS-232 mode.
 CONFIG	SETTINGS LOCK	Lock or unlock settings.
	SAVE CONFIG	Save the current configuration.
	RESTORE CONFIG	Load a saved configuration.
	RESET INPUT NAMES	Reset the input names to default.
	FACTORY RESET	Restore standard factory settings.
 DISPLAY	BRIGHTNESS	Adjust the display brightness.
	DISPLAY ON/OFF	Set the display to automatically switch off after a period of inactivity.
	LOGO ON/OFF	Turn the dCS logo light on and off.
 GENERATOR	CHANNEL CHECK	Test the system for swapped channels.
	PHASE CHECK	Test the system for phase reversals.
	BURN IN	Output modulated pink noise to burn-in the unit.



To move up a level in the menus, select **RETURN** .

Renaming digital inputs

To help identify inputs connected to the Bartók Headphone DAC, you can rename them. You need to connect the unit to a computer and run a terminal emulator program to rename the inputs. Example terminal emulator programs include Tera Term, PuTTY, or ZTerm.

To rename the digital inputs using Tera Term on a Windows™ computer:

1. Download and install Tera Term on a computer.
2. On your Bartók Headphone DAC, change the RS-232 option to **Text**.
 - ▶ *For more information, see "RS-232 socket" on page 14.*
3. Use a USB-to-RS-232 adapter cable to connect the RS-232 socket on the unit to a USB socket on the computer.
4. Run Tera Term on the computer.
5. Select **Serial**.
6. Select **OK** to connect to your Bartók Headphone DAC.
7. Select **Setup > Serial Port**.
8. In the **Baud rate** field, enter 115200.
9. Select **OK**.
10. In the terminal window, enter the command: `NAME n = newname`, where:

`n` is the number of the standard input name:

0	AES1	4	SPDIF2
1	AES2	5	SPDIF3
2	AES1 + 2	6	Network
3	SPDIF1	7	USB1

`newname` is the personalised name, which can be up to 8 characters long.

For example, to rename the USB1 input to **Laptop**, enter `NAME 7 = Laptop`.

11. Press the Enter key to update the input name.
12. Rename any other inputs, then close Tera Term and disconnect the computer from your Bartók Headphone DAC.



You can revert the inputs to their default names.

- ▶ *For more information, see "Resetting input names" on page 42.*

Renaming your Bartók Headphone DAC

To help identify your Bartók Headphone DAC on a network, you can rename it.

1. Connect a PC, laptop or mobile device to the same network as Bartók Headphone DAC.
2. Press the *Menu* button three times.
Make a note of the IP address that is displayed.
3. Press the *Power* button to close the menu.
4. On your PC, laptop or mobile device, open a browser and enter the IP address of your Bartók Headphone DAC in the address bar.
The web client opens.
5. Select **Device Settings**.
6. Edit the **Device Name** field and select **Submit**.

Viewing information about the unit

1. Press the *Menu* button.
2. Select **INFO**.
3. Press the *Menu* button to select an option.

-
-  Unit status. Displays the unit status, including:
- Serial number
 - Network name
 - Internal temperature
 - IP address
 - The frequency detected on each word clock input
 - The sample rate detected on each input
 - Headphone amplifier status

This information can help you find setup or connection errors.

-
-  Version. Displays the main software version and network firmware version. You may need this information when contacting your dealer.



-
-  Contact. Displays contact details for dCS.

-
-  Update. For service use only. Use the Mosaic Control app to update the product.
-

Audio settings

Changing the absolute phase of analogue outputs

When listening to music, if the character of the instruments sounds wrong then it may be because the track was recorded with both channels phase-inverted. You can correct the absolute phase of the outputs.

1. Press the *Menu* button.
 2. Select **AUDIO SETTINGS > PHASE**.
 3. Press the *Menu* button to change between normal phase  and inverted phase .
- This setting is reset when you next switch the unit on.

Changing the PCM filter

You can use the filter settings to change how music sounds when listening to PCM data. Filters are a personal choice. A different filter setting is stored for each sample rate.





1. Press the *Menu* button.
2. Select **AUDIO SETTINGS > FILTER**.
3. Press the *Menu* button to change the PCM filter.

F1	Filter 1. The filter has the best rejection of unwanted Nyquist images with the sharpest roll-off, and the poorest transient response of the first four filters.
F2	Filter 2. The filter has a more relaxed image rejection and better transient response. Filter 2 is recommended for orchestral music.
F3	Filter 3. The filter has a more relaxed image rejection and better transient response than Filters 1 and 2. Filter 3 is recommended for rock music.
F4	Filter 4. The filter has the lowest image rejection and the best transient response of the first four filters. Filter 4 is also recommended for rock music.
F5	Filter 5. If the sample rate is 176.4, 192, 352.8, or 384 kS/s, the filter has a Gaussian response, which offers no overshoot on transients and a relaxed roll-off. If the sample rate is 44.1 kS/s, the filter is an asymmetrical design, which features almost no pre-ringing. Filter 5 is not available if the sample rate is 48, 88.2 or 96 kS/s
F6	Filter 6. If the sample rate is 176.4, 192, 352.8, or 384 kS/s, the filter is an asymmetrical design, which features almost no pre-ringing. If the sample rate is 44.1 kS/s, the filter is an alternative sharp filter, which has linear phase and pre-ringing. Filter 6 is not available if the sample rate is 48, 88.2 or 96 kS/s.
M1	Filter M1. Recommended and only available for MQA audio files. You can select this filter in addition to the other PCM filters.

Changing the DSD filter



The DSD filter is active when you are playing DSD files or upsampling PCM data to DSD.

1. Press the *Menu* button.
2. Select **AUDIO SETTINGS > DSD FILTER**.
3. Press the *Menu* button to change the DSD filter.

	Filter 1. The default setting, which gives the widest bandwidth and the highest level of out-of-band noise.
	Filter 2. Reduces the out-of-band noise and bandwidth.
	Filter 3. Reduces the out-of-band noise and bandwidth further.
	Filter 4. Recommended for troubleshooting only. Sharply reduces the out-of-band noise and also limits the bandwidth to 25 kHz.
	Filter 5. Has a relaxed roll-off with a smoother phase response. Removes much of the out-of-band noise.

Swapping channel connections

You can swap channels to correct a connection error.

1. Press the *Menu* button.
 2. Select **AUDIO SETTINGS > CH SWAP**.
 3. Press the *Menu* button to choose normal channels  or swapped channels .
- This setting is reset when the unit is next switched on.





Changing the crossfeed setting

Crossfeed is the process of blending left and right channels of a stereo audio recording, to help make audio sound more natural when played through headphones. The crossfeed setting that is most suitable for you and the music you are listening to may vary, so we recommend testing the different settings.

dCS Expanse

Expanse is the new patent-pending crossfeed processing algorithm developed by dCS. It applies different processing filters to give two different responses: E1 and E2. With Expanse, there is a unique headphone listening experience for all listeners that stays true to the original recording.

1. Press the *Menu* button.
2. Select **AUDIO SETTINGS > CROSSFEED**.
3. Press the *Menu* button to change the crossfeed setting.

	Crossfeed off. The two audio channels are presented to the headphones in the usual way.
	Crossfeed on. Some of the signal from one channel is filtered and mixed with the other channel to better imitate listening to loudspeakers in a room.
	Expanse E1. A crossfeed processing algorithm that uses different processing filters.
	Expanse E2. A crossfeed processing algorithm that uses different processing filters.

Adjusting the balance

You can adjust the audio balance.

 You can only adjust the balance in line output mode.

1. Press the *Menu* button.
2. Select **AUDIO SETTINGS > BALANCE**.
3. Press the *Menu* button to open the balance adjust screen.
4. Use the rotary control to adjust the balance in 0.1 dB steps from 0 to –6 dB.

Mute is represented by $-\infty$.



Balance set to the left.



Balance set to the centre.



Balance set to the right.

5. Press the *Menu* button to return the control to volume adjustment.

Unit settings

Setting the clocking sync mode

You can change the clocking sync mode for the current digital input. The sync mode setting is stored separately for each input.

1. Press the *Menu* button.
2. Select **UNIT SETTINGS > SYNC MODE**.
3. Press the *Menu* button to change the sync mode.



Audio. The unit extracts the clock from the data stream connected to the input and locks to it. Recommended for sources that do not have a suitable Word Clock input. Cannot be selected for USB or network inputs.



Master. The unit uses its own internal clock and outputs a clock to the source device. This is the normal mode for the USB and network inputs when a Master Clock is not available. When using AES or SPDIF inputs in Master Mode, the unit outputs a clock signal at the *WORD CLOCK OUT* connection, which must be connected to the Word Clock input of the source device.



Word Clock 1-2 Auto. The unit automatically locks to the appropriate clock connected to *WORD CLOCK 1* and *WORD CLOCK 2*. Recommended for systems with a Master Clock in a computer audio system, as the data rate of the music may keep changing.

- Connect the *WORD CLOCK 1* input to a Master Clock output set to 44.1, 88.2, or 176.4 kHz.
- Connect the *WORD CLOCK 2* input to a Master Clock output set to 48, 96, or 192 kHz.



Word Clock In 1. The unit locks to an external clock connected to *WORD CLOCK 1*.



Word Clock In 2. The unit locks to an external clock connected to *WORD CLOCK 2*.



If the unit can't find a word clock that is synchronous with the data on the current AES or SPDIF input, it defaults to audio sync. The incorrect clock icon  is displayed.

Changing the mapper

The mapper controls how data is presented to the Ring DAC core. Bartók Headphone DAC includes three mapper designs.

1. Press the *Menu* button.
2. Select **UNIT SETTINGS > MAPPER**.
3. Press the *Menu* button to change the mapper.



Mapper 1. The new default mapper design, which drives the Ring DAC core at either 5.644 or 6.14 MHz.



Mapper 2. The classic mapper design, used on version 1 dCS products. This mapper design drives the Ring DAC core at either 2.822 or 3.07 MHz.





Mapper 3. An alternative mapper design, which drives the Ring DAC core at either 5.644 or 6.14 MHz.

Changing the output mode

You can use either the line outputs on the rear panel or the headphone outputs on the front panel.

Select the OUTPUT MODE:

1. Press the *Menu* button.
2. Select **UNIT SETTINGS > OUTPUT MODE**.
3. Press the *Menu* button to change between line outputs  and headphone outputs .

Changing the line output level

You can change the maximum line output level to match your amplifiers, speakers, and room. The difference between two adjacent settings is about 10 dB.

 The DAC stores separate volume and output level settings for the line outputs and the headphone outputs.

1. Press the *Menu* button.
2. Select **UNIT SETTINGS > OUTPUT LEVEL**.
3. Press the *Menu* button to change the setting.
You can set the line output level to 6V, 2V, 0.6V, or 0.2V rms.

Changing the headphone output level

You can set the maximum headphone output level to match your headphone sensitivity, your choice of music and your listening habits.

Choose a headphone output level that gives a comfortable listening level with the volume set between -10 dB and -30 dB.



 The DAC stores separate volume and output level settings for the line outputs and the headphone outputs.

1. Press the *Menu* button.
2. Select **UNIT SETTINGS > HP LEVEL**.
3. Press the *Menu* button to change the setting.
You can set the line output level to 0, -10, -20 or -30 dB.

Enabling and disabling Dual AES

You can set the AES1 and AES2 inputs to be used together to accept PCM data from a Dual AES source, at 88.2 kS/s or more.

1. Press the *Menu* button.
2. Select **UNIT SETTINGS > AES1/2 DUAL**.
3. Press the *Menu* button to change the setting.

-
- | | |
|---|--|
|  | Off. Disables Dual AES mode. Each AES input accepts single AES data. |
|  | On. Enables manual selection between Single AES or Dual AES mode. |
|  | Auto. The unit detects the data format and automatically selects Single or Dual AES. |
-

Setting the USB audio class

The *USB1* socket supports two audio classes: Class 1 and Class 2.

► For more information, see "*USB sockets*" on page 13.



NOTICE

Before changing the USB audio class, stop playback and close any relevant audio applications on the connected computer.



On Apple desktops and notebooks running macOS 10.6.3 or later, or computers running Windows™ 10 or later, no additional driver needs to be installed.

On computers running Windows™ 7, 8 or 8.1, the dCS USB Class 2 audio driver needs to be installed. If you require the dCS USB Class 2 audio driver, contact dCS support at support@dcsaudio.com.



1. Press the *Menu* button.
2. Select **UNIT SETTINGS > USB CLASS**.
3. Press the *Menu* button to change between Class 1  and Class 2 .

After you select a different audio class, wait for 10 seconds while the USB software reloads.

Enabling and disabling the buffer

By default, there is a buffer delay in the unit. This buffer delay mutes the unit before you hear audible clicks caused by changes in sample rate or clock frequency. The delay is 0.72 seconds with 44.1 kS/s data, and 0.16 seconds with 192kS/s data.

If the unit is connected to a television or video equipment, you may need to disable the buffer to keep the sound in sync with the picture.

1. Press the *Menu* button.
2. Select **UNIT SETTINGS > BUFFER MODE**.
3. Press the *Menu* button to enable  or disable  the buffer.

Enabling and disabling DSD upsampling

You can select between three processing options when receiving PCM data.

1. Press the *Menu* button.
2. Select **UNIT SETTINGS > UPSAMPLING**.
3. Press the *Menu* button to change the setting.

DXD	DXD. The unit uses its standard PCM oversampling process for PCM data.
DSD	DSD. The unit adds a DSD upsampling step before the end of the PCM oversampling process.
DSDx2	DSDx2. The unit adds a DSDx2 upsampling step before the end of the PCM oversampling process.

Changing the RS-232 mode

You can change the operating mode of the RS-232 socket.

► For more information, see "*RS-232 socket*" on page 14.

1. Press the *Menu* button.
2. Select **UNIT SETTINGS > RS232 MODE**.
3. Press the *Menu* button to change between text mode ▶**T** and binary mode ▶**B**.



Configuration settings

Locking settings

When settings are locked, you cannot change the following:

- Sync mode for all inputs
- Output level
- Dual AES
- Channel swap
- Balance
- DSD filter
- USB1 audio class
- RS-232 mode

When the settings are locked, you cannot save or restore configurations, or perform a factory reset.

1. Press the *Menu* button.
2. Select **CONFIG > SETTINGS LOCK**.
3. Press the *Menu* button to lock  or unlock  the settings.

Saving a system configuration

You can save the current system configuration to the unit's memory.

1. Press the *Menu* button.
2. Select **CONFIG > SAVE CONFIG**.
3. Press the *Menu* button to confirm the save.

Restoring a system configuration

If you change the settings accidentally, you can restore the configuration that was saved previously.

1. Press the *Menu* button.
2. Select **CONFIG > RESTORE CONFIG**.
3. Press the *Menu* button to confirm the restore.

Resetting input names

You can reset any changes that you made to input names.

1. Press the *Menu* button.
2. Select **CONFIG > RESET INPUT NAMES**.
3. Press the *Menu* button to confirm the reset.

Resetting to factory conditions

You can reset the settings to factory conditions.

1. Press the *Menu* button.
2. Select **CONFIG > FACTORY RESET**.
3. Press the *Menu* button to confirm the factory reset.

The default settings are below.

Setting	Value
Volume	-30 dB
Balance	Centre
Input	Network
OUTPUT MODE	Line
SYNC MODE	AUDIO for all inputs except USB and Network WORD CLOCK 1-2 AUTO for USB and Network
FILTER	1 for all sample rates
DSD FILTER	1
AES1/2 DUAL	Auto
PHASE	Normal
OUTPUT LEVEL	2 V
HP LEVEL	-30 dB
CROSSFEED	Off
DISPLAY ON/OFF	On
BRIGHTNESS	Maximum
CH SWAP	Normal
BUFFER MODE	On
UPSAMPLING	DSD
LOGO ON/OFF	On

Display settings



Changing the display brightness

You can change the display brightness.

1. Press the *Menu* button.
2. Select **DISPLAY > BRIGHTNESS**.
3. Press the *Menu* button to open the brightness adjust screen.
4. Adjust the brightness with the ◀ or ▶ buttons.
5. Press the *Menu* button to confirm the setting.



Automatically switching the display off

You can set the display to automatically switch off after a period of inactivity.

1. Press the *Menu* button.
2. Select **DISPLAY > DISPLAY ON/OFF**.
3. Press the *Menu* button to enable  or disable  the setting.
When the menu is open on the unit, the display stays on in both settings.

Enabling and disabling the dCS logo light

You can enable or disable the dCS logo light that is next to the display.

1. Press the *Menu* button.
2. Select **DISPLAY > LOGO ON/OFF**.
3. Press the *Menu* button to enable  or disable  the setting.

System tests

Testing for swapped channels

You can test the system for swapped channels.

1. Press the *Menu* button.
2. Select **GENERATOR > CHANNEL CHECK**.
3. Press the *Menu* button to start the test.

The unit outputs a tone on the left channel and then the right channel. If what you hear does not match what is shown on the display, check for swapped channels.

Testing for phase reversals

You can test the system for phase reversals.

1. Press the *Menu* button.
2. Select **GENERATOR > PHASE CHECK**.
3. Press the *Menu* button to start the test.

The unit outputs noise on both channels and displays **In Phase**. The unit then inverts the noise on the right channel and displays **Out of Phase**. The first action should produce a central stereo image and the second action should not. If the opposite occurs, one channel in the system is phase inverted. Check for connection errors.

Conditioning the unit

You can run a procedure to condition the unit. The system outputs modulated pink noise that increases and decreases.

NOTICE

Conditioning the unit at high volumes can damage amplifiers and loudspeakers. Before conditioning the unit, reduce the volume to a low level. dCS is not liable for any damage to equipment due to incorrect use of the conditioning feature.

1. Press the *Menu* button.
2. Select **GENERATOR > BURN IN**.
3. Press the *Menu* button to start conditioning the unit.
While the condition is in progress, press any button to stop it.

Updating the software

You can update the software on the Bartók Headphone DAC using the Mosaic Control app.

1. On your mobile device, open the Mosaic Control app.
2. Select  > **SUPPORT > Versions > Check for updates**.
3. If an update is available, follow the instructions to complete the update.

NOTICE

A software update can take up to 45 minutes. Do not switch off the unit until the software update is confirmed on the display.

Specifications

Converter type	dCS proprietary Ring DAC™ topology.
Digital inputs	<p>UPnP Network interface on an RJ45 connector streams music files from a NAS or local computer using MinimServer over an Ethernet network. Supported file formats are:</p> <ul style="list-style-type: none"> • FLAC, AIFF & WAV – up to 24-bit PCM at 44.1, 48, 88.2, 96, 176.4, 192, 352.8 or 384kS/s • ALAC – up to 24-bit PCM at 44.1, 48, 88.2, 96, 176.4 & 192kS/s • AAC, MP3 - up to 24-bit PCM at 44.1 or 48kS/s • DFF, DSF and DoP – DSD/64 and DSD/128 <p>Supports TIDAL, Qobuz, Deezer, Internet Radio and Podcasts via Airable. The interface accepts audio data streamed from a suitable mobile device via Apple AirPlay at 44.1 or 48kS/s. The Network interface operates in Asynchronous mode.</p> <hr/> <p>USB1 interface on a B-type connector will accept up to 24-bit PCM at:</p> <ul style="list-style-type: none"> • 44.1, 48, 88.2 or 96kS/s when set to USB Class 1 (no driver required). • 44.1, 48, 88.2, 96, 176.4, 192, 352.8 or 384kS/s when set to USB Class 2. On Apple desktops and notebooks running macOS 10.6.3 or later, or computers running Windows™ 10 or later, no additional driver needs to be installed. • In USB Class 2, passes through DSD/64 & DSD/128 in DoP format. <p>The USB1 interface operates in Asynchronous USB mode.</p> <hr/> <p>USB2 interface on A-type connector, streams audio files from a USB flash drive up to 24-bit PCM at 44.1, 48, 88.2, 96, 176.4, 192, 352.8 or 384kS/s or DSD/64 or DSD/128. Compatible formats are listed in the UPnP Network interface section above. Maximum power delivery is 2.1 A at 5 V DC. The USB2 interface operates in Asynchronous USB mode.</p> <hr/> <p>2x AES/EBU on 3-pin female XLR connectors. Each input will accept up to 24-bit PCM at 44.1, 48, 88.2, 96, 176.4 or 192kS/s or DSD/64 in DoP format. As a Dual AES pair: at 88.2, 96, 176.4, 192, 352.8 or 384kS/s or dCS-encrypted DSD or DSD/64 & DSD/128 in DoP format.</p> <hr/> <p>2x SPDIF on 1x RCA Phono and 1x BNC connectors. Each will accept up to 24-bit PCM at 44.1, 48, 88.2, 96, 176.4 or 192kS/s or DSD/64 in DoP format.</p> <hr/> <p>1x SPDIF optical on a Toslink connector, will accept up to 24-bit PCM at 44.1, 48, 88.2 or 96kS/s.</p>
Clocking	<p>2x Word Clock Inputs on 2x BNC connectors, accept standard word clock at 44.1, 48, 88.2, 96, 176.4 or 192kHz. The data rate can be the same as the clock rate or an exact multiple (0.25x, 0.5x, 1x, 2x, 4x, 8x) of the clock rate. Sensitive to TTL levels.</p> <hr/> <p>Word Clock Output on 1x BNC connector. In Master mode, a TTL-compatible word clock appears on this output, not temperature compensated. The word clock frequency is either 44.1 or 48kHz, depending in the incoming data rate.</p>
MQA	Full decoding and rendering of MQA data from the Network and USB2 inputs. Final rendering of unfolded MQA data only from the other inputs.

Frequency response (set to Filter 1)	Fs = 44.1 or 48kS/s	+/-0.1dB, 10Hz to 20kHz	
	Fs = 88.2 or 96kS/s	+/-0.1dB, 10Hz to 20kHz	-3dB @ >38kHz
	Fs = 176.4 or 192kS/s	+/-0.1dB, 10Hz to 20kHz	-3dB @ >67kHz
	Fs = 352.8 or 384kS/s	+/-0.1dB, 10Hz to 20kHz	-3dB @ >100kHz
	DSD/64	+/-0.1dB, 10Hz to 20kHz	-3dB @ >90kHz
	DSD/128	+/-0.1dB, 10Hz to 20kHz	-3dB @ >100kHz
Residual noise (6V output setting)	16-bit data: Better than -96dB0, 20Hz - 20kHz unweighted. 24-bit data: Better than -113dB0, 20Hz - 20kHz unweighted.		
Upsampling	Optional 1-bit 2.822 or 3.07MS/s upsampling (set in the menu) to supplement the multi-stage PCM oversampling.		
Spurious responses	Better than -105dB0, 20Hz - 20kHz.		
L-R crosstalk	Better than -115dB0, 20Hz - 20kHz.		
Line outputs	1 stereo balanced pair on 2x 3-pin male XLR connectors (pin 2 = hot, pin 3 = cold). These outputs are electronically balanced and floating, the signal balance ratio at 1kHz is better than 40dB. Output impedance is 3Ω, maximum load is 600Ω (a 10kΩ - 100kΩ load is recommended). 1 stereo unbalanced pair on 2x RCA Phono connectors. Output impedance is 52Ω, maximum load is 600Ω (a 10kΩ - 100kΩ load is recommended). Output levels are 6V, 2V, 0.6V or 0.2V rms or a full-scale input, set in the menu.		
Headphone outputs	1 stereo balanced pair on 1x 4-way female XLR connector. 1 stereo unbalanced pair on 1x 6.35mm (1/4") 3-pole jack. Full-scale output levels are 1.4W rms into 33Ω, 0.15W rms into 300Ω. Output levels are 0, -10, -20, -30dB, set in the menu. Minimum headphone impedance is 30Ω.		
Size and weight	444mm (17.5") wide x 430mm (17.0") deep x 115mm (4.6") high. Allow extra depth for cable connectors. Allow space for air flow around the unit. 15.7kg (34.7lbs).		
Power requirements	Internally set to either 100, 115/120, 220 or 230/240V AC, 50/60Hz. Power consumption: 30W typical, 50W maximum. Consumes less than 0.5W when powered down from the front panel.		



These specifications are subject to change without notice.

About the software

dCS products make extensive use of software configurable chips – FPGAs and DSPs. This gives us the ability to update our products to add extra features, update digital interface standards or make performance improvements by loading new software. Occasionally, a hardware upgrade may be necessary also to increase the “capacity” of the electronics, add extra connectors or extra front panel controls.

Please note that not all software updates produce an audible improvement. We recommend that you keep your software up to date. Check the dCS web-site occasionally for news of the latest software updates.

This manual is for Bartók Headphone DAC software version 2.0x.

Maintenance

dCS audio products do not need regular maintenance. The only user-serviceable part of the unit is the mains fuse. If the unit is damaged, contact your fulfilment centre.

Replacing a blown mains fuse

There is a fuse below the power inlet of the unit. If the fuse blows, you can replace it.

- If the fuse blows once, replace the fuse. There was a power surge.
- If the fuse blows repeatedly, contact your dealer to arrange repair. There is a fault in the unit.

Fuse type: 20 x 5mm T 1A L



WARNING

Replace the fuse with one of the same type and rating. If you use a fuse of a different type or rating, it may damage the unit and there is a risk of fire or electric shock. It also invalidates the warranty.

To replace a blown mains fuse:

1. Unplug the power cable from the unit.
2. Next to the power rocker switch, push the two tabs of the fuse holder towards the centre and pull out the fuse holder.

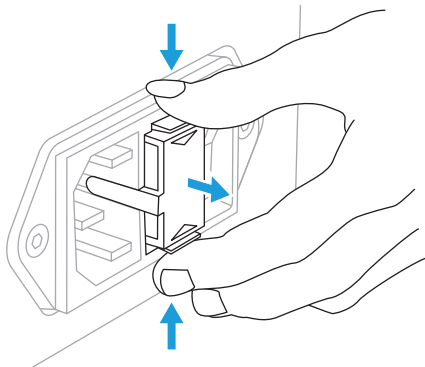

3. Remove the blown fuse from the lower position of the fuse holder.

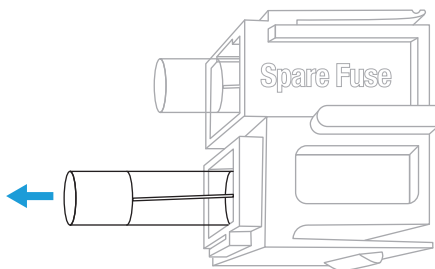

4. Replace the blown fuse with the spare fuse from the upper position.

5. Push the fuse holder back into the unit with the writing the correct way up, until you hear a click.

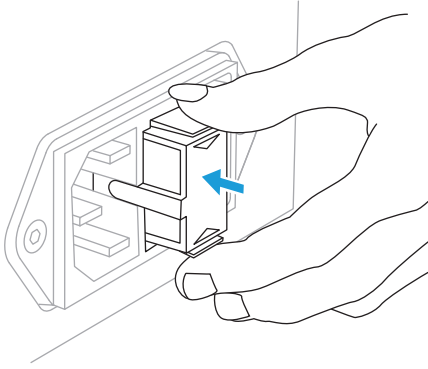

Cleaning the unit

If the case of the unit gets dusty or dirty, you can clean it with a lint-free cloth.

- To remove fingerprints and loose dust, use a clean and dry lint-free cloth.
- To restore the finish of the unit, use a small amount of lanolin-based cleaner and a lint-free cloth. Ensure that lanolin does not collect around the buttons on the unit.
- To clean any other surfaces, such as the display, use a small amount of glass cleaner containing ammonia and a lint-free cloth. Do not spray glass cleaner directly onto the connector contacts.

Troubleshooting



If the unit is not working correctly, you can view status information about the unit in the menu.

► For more information, see "Viewing information about the unit" on page 34.

Problem	Cause	Solution
Unit doesn't switch on.	Supply voltage is incorrect.	Check if the voltage on the back of the unit is the same as your local supply voltage.
	Power cable is not connected.	Connect the power cable. ► For more information, see "Connecting the power supply" on page 16.
	Power rocker is in the O (off) position.	On the rear of the unit, switch the power rocker to the I (on) position. ► For more information, see "Switching the unit on and off" on page 16.
	Mains fuse is blown.	Replace the mains fuse. ► For more information, see "Replacing a blown mains fuse" on page 48.
The display keeps turning off.	The display is set to automatically turn off after a period of inactivity.	Change the display setting. ► For more information, see "Automatically switching the display off" on page 44.
Unit doesn't respond.	Unit is in sleep mode.	Wake up the unit. ► For more information, see "Switching the unit on and off" on page 16.
No input is displayed.	The cables are connected incorrectly.	Check the cables are securely connected to the correct sockets.
There are crackles, pops or other noises while playing music.	The cable is damaged or of the wrong type.	Check if the cable is damaged and that you are using a recommended cable. ► For more information, see "Recommended cables and connectors" on page 7.
	The source content is damaged or interrupted.	Play different content to see if the problem is still present.
	If a CD transport is connected, the CD is dirty or damaged.	Clean the CD.
Cannot connect PC or laptop.	The USB1 firmware is corrupted.	Change the USB audio class. ► For more information, see "Setting the USB audio class" on page 40.
	The operating system on the PC or laptop is out of date.	Check the requirements for connecting a computer. ► For more information, see "Connecting a computer" on page 21.

Problem	Cause	Solution
USB storage device is not detected.	The format of the storage device is incorrect.	Connect a USB storage device that is formatted as FAT16, FAT 32, or unencrypted NTFS.
	The reading time is slow.	High-capacity drives can take long time to read and process. Use a USB storage device that has a smaller capacity.
	USB device was removed while the music was playing.	Restart the unit. Stop playback or change the input before disconnecting the drive.
Mosaic Control app cannot connect to the unit.	The unit and the Mosaic Control app are not connected on the same network.	Connect them on the same network.
	The IP address of the unit is not valid.	Correct the IP address.
	The Mosaic Control app connection timed out.	Restart the app.
	Mosaic Control app is out of date.	Update the app.

Support

If you need help using your Bartók Headphone DAC, contact your dealer. If your dealer cannot help, contact your national distributor and provide them with the serial number and software versions.

Contact details

Manufactured by:

Data Conversion Systems Ltd.
Unit 1, Buckingham Business Park,
Anderson Road,
Swavesey,
Cambridgeshire,
CB24 4AE,
UK

www.dcsaudio.com

You can download this user manual free of charge from our website. To order a printed copy of this user manual, contact dCS.

Limited warranty

General information

dCS warrants this product against defects in materials and workmanship for a period of 3 years from the date the unit was originally shipped from dCS. If the product is purchased and registered with dCS within 6 months of the date the unit was originally shipped from dCS, we will start the warranty on the purchase date. For units registered later than 6 months from the ship date, we will start the warranty from the ship date unless the registration is supported by the original sales invoice. During the first year of the warranty period, dCS will repair or, at our absolute discretion, replace a faulty product. For the remaining two years, service will be covered, but any parts needed will be chargeable. Warranty repairs must only be carried out by dCS or our authorised service agents. Please contact your fulfilment centre if your unit requires service.

To register this product, either register online at www.dcsaudio.com/register or complete the Product Registration form within 30 days of the sale and return it to dCS. On receipt of the registration, dCS will add your contact details to our customer database. dCS will use this information for warranty purposes only, we will not contact you directly for reasons relating to sales and marketing.

This warranty applies to the original owner, it is not transferable.

Warranty exclusions

The warranty does not cover wear and tear.

The warranty on this product will be void if:

- the product is misused in any way.
- any unauthorised modifications or repairs are carried out.
- the product is not used in accordance with the Operating Conditions stated in this manual.
- the product is serviced or repaired other than by dCS or our authorised service agents.
- the product is operated without a mains earth (or ground) connection.
- the unit is returned inadequately packed.

dCS reserve the right to apply a service charge if a product returned for warranty repair is found to be operating correctly, or if a product is returned without a returns number being issued.

This warranty covers parts and labour only, it does not cover shipping charges or tax/duty.

Our fulfilment centres and service agents are not authorised to extend the terms of this warranty, dCS cannot accept responsibility for any attempt to do so.

Products re-sold by dCS on a “used” basis may be subject to reduced warranty terms.

Obtaining service

Should you encounter a problem, contact your fulfilment centre or authorised service centre for help, quoting the model, the serial number, the software version (where appropriate) and giving a detailed description of the fault. Your contact will advise you fully on actions that need to be taken. When returning a unit, the original packaging should be used to avoid transit damage. Replacement packaging sets may be purchased from dCS.

Operating conditions

- The supply voltage must remain within +/-10% of the A.C. voltage specified on the back panel.
- The supply frequency must be in the range 49 Hz to 62 Hz.
- Ambient temperature range: 0°C (32°F) to 45°C (113°F), non-condensing.
- Do not install the unit near heat sources such as radiators, air ducts, power amplifiers or direct strong sunlight.

Compliance

FCC compliance statement



This equipment has been tested and found to comply with the limits for a Class B digital device, pursuant to part 15 of the FCC Rules.

These limits are designed to provide reasonable protection against harmful interference in a residential installation. This equipment generates, uses and can radiate radio frequency energy and, if not installed and used in accordance with the instructions, may cause harmful interference to radio communications. However, there is no guarantee that interference will not occur in a particular installation.

You can determine whether this equipment is causing interference by turning it off. If the interference stops, it was probably caused by the equipment or a peripheral device.

If your equipment does cause interference to radio or television reception, try to correct the interference by one or more of the following measures:

- Turn the television or radio antenna until the interference stops.
- Move the equipment to one side or the other of the television or radio.
- Move the equipment further way from the television or radio.
- Plug the equipment into an outlet that is on a different circuit from the television or radio. (That is, make certain the equipment and the television or radio are on circuits controlled by different circuit breakers or fuses.)

(USA only) If necessary, consult dCS Americas LLC or an experienced radio / television technician for additional suggestions.

Changes or modifications not expressly approved by dCS Americas LLC could void the manufacturer's warranty.

This product has demonstrated electromagnetic interference compliance under conditions that included the use of compliant peripheral devices and shielded cables between system components. In order to maintain compliance with FCC regulations, shielded cables (including Ethernet network cables) must be used with this equipment. Operation with non-approved equipment or unshielded cables is likely to result in interference to radio and TV reception.

Responsible party (contact for FCC matters only)

dCS Americas LLC,
PNC Bank Bldg,
300 Delaware Ave, Suite 210,
Wilmington, DE 19801,
USA

Made for iPhone® and iPad®



“Made for iPad” and “Made for iPhone” mean that an electronic accessory has been designed to connect specifically to iPad or iPhone respectively and has been certified by the developer to meet Apple performance standards. Apple is not responsible for the operation of this device or its compliance with safety and regulatory standards.

Bartók Headphone DAC has been certified with the following products:

- iPhone X
- iPhone 8 Plus
- iPhone 8
- iPhone 7 Plus
- iPhone 7
- iPhone SE
- iPhone 6s Plus
- iPhone 6s
- iPhone 6 Plus
- iPhone 6
- iPhone 5s
- iPhone 5
- iPad Pro (10.5 inch)
- iPad Pro (12.9 inch) 2nd Generation
- iPad Pro (12.9 inch) 1st Generation
- iPad mini 4
- iPad mini 3

Bartók Headphone DAC supports iOS 7 or later for setup using Wireless Accessory Configuration.

Works with Apple AirPlay



Use of the Works with Apple AirPlay badge means that an accessory has been designed to work specifically with the technology identified in the badge and has been certified by the developer to meet Apple performance standards.

AirPlay works with iPhone, iPad, and iPod touch, or Mac and PC with iTunes.

Apple, AirPlay, Mac, iTunes, iPad and iPhone are trademarks of Apple Inc., registered in the U.S. and other countries. tvOS is a trademark of Apple Inc.. The trademark "iPhone" is used in Japan with a license from Aiphone K.K.